

REALITY ORIENTED SIMULATION MODELS OF THE HYDRO POWER PLANTS IN MACEDONIA AND SERBIA/MONTENEGRO

F. Prillwitz, A. Holst, H. W. Weber

University of Rostock – A.-Einstein-Str. 2, D-18059 Rostock, Germany

Summary. In hydro power plants of Macedonia (MK) and Serbia and Montenegro (SiM) there is a very high interest in investigations concerning the static and dynamic behaviour of the units. This contribution presents the most important steps for a reality oriented creation of mathematical models of hydro power plants. Therefore in the investigated hydro power plants “Vrutok” (MK), “Zvornik” (SiM), “Tikves” (MK), “Bajina Basta” (SiM) and “Djerdap” (SiM) measurements were performed to obtain step response time signals of all important functional parts of the plants. Using the least-square-method with the Matlab-software it was possible to identify all the necessary parameters of the mathematical models.

Keywords: dynamic behaviour, dynamic modelling, hydro power plant, identification, simulation

INTRODUCTION

The stabilization of the research and education capabilities in the universities of the Balkan Countries is one of the most important aims of the European Community in the so called Stability Pact for South Eastern Europe.



Stabilitätspakt für Südosteuropa
Gefördert durch Deutschland
Stability Pact for South Eastern Europe
Sponsored by Germany

The further described project is part of the Stability Pact for South Eastern Europe and was supported by the German Academic Exchange Service.

In the hydro power plants of Macedonia and Serbia and Montenegro there is a lack of knowledge and information about the static and dynamic behaviour of the units for each contingency that could occur. In this context the Institute of Power Electrical Engineering of the University of Rostock established research and

education contacts to the University of Skopje, Macedonia and the University of Belgrade, Serbia and Montenegro. At the same time the problems were discussed with the Electric Power Company of Macedonia (ESM) in Skopje and the Electric Power Industry of Serbia (EPS) in Belgrade respectively. With these contacts it was possible with assistance of professors, assistants and students of the respective faculties and with engineers and specialists from the companies to construct dynamic simulation models of hydro power plants necessary for overall simulation models of the whole power systems of the involved countries. Later these overall simulation models can be used by the staff involved with the operation and maintenance of the plant for their training but also by experts for investigations like [1],[2]:

- Black Start Capabilities after Black Out
- Behavior in isolated operation
- Primary and secondary power reserve capabilities
- Reduction of losses in the plants
- Overall dynamic behavior of the whole system including stability investigations.

The authors investigated dynamic characteristics of hydro power plants with Pelton turbines, HPP “Vrutok” (MK), with Francis turbines, HPP “Tikves” (MK), HPP “Bajina Basta” (SiM) and with Kaplan turbines, HPP “Zvornik” (MK), HPP “Djerdap” (SiM), see Fig. 1. It will be shown, that a model structure developed using the documentations of the power plants together with parameter estimations after suitable experiments will lead to comparatively small simulation models which can guarantee a very good dynamic behaviour compared with the behaviour of real power plants.

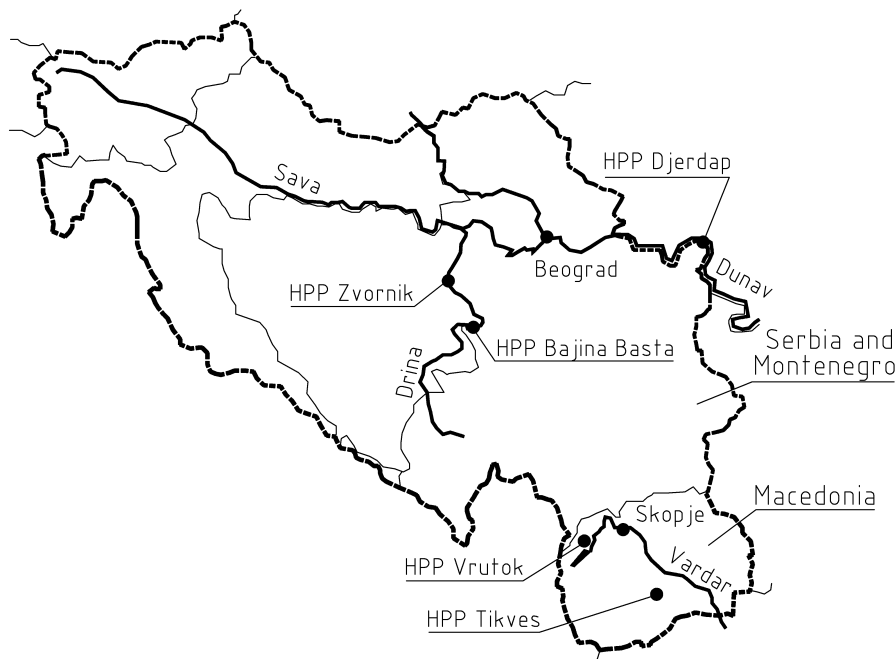

Fig. 1 Map of the investigated hydro power plants in Macedonia and Serbia / Montenegro

INVESTIGATED HYDRO POWER PLANTS

The HPP “Vrutok” lies in the north-western part of the Republic of Macedonia, 7 km on the west of Gostivar city and 64 km on the south-west of Skopje. Together with the “Mavrovo Lake” and the HPP “Vrben” and HPP “Raven”, it forms a cascade system. The HPP “Vrutok” is the largest hydro power plant in Macedonia and with the Mavrovo accumulation lake has an irreplaceable role in the regulation of the load-frequency control and electricity consumption daily diagram. It’s role in restoration studies could be of the highest importance. The HPP “Vrutok” with the entire hydro and electromechanical equipment is arranged in an underground building. It is a derivational, storage type of hydro power plant, see Fig.2.

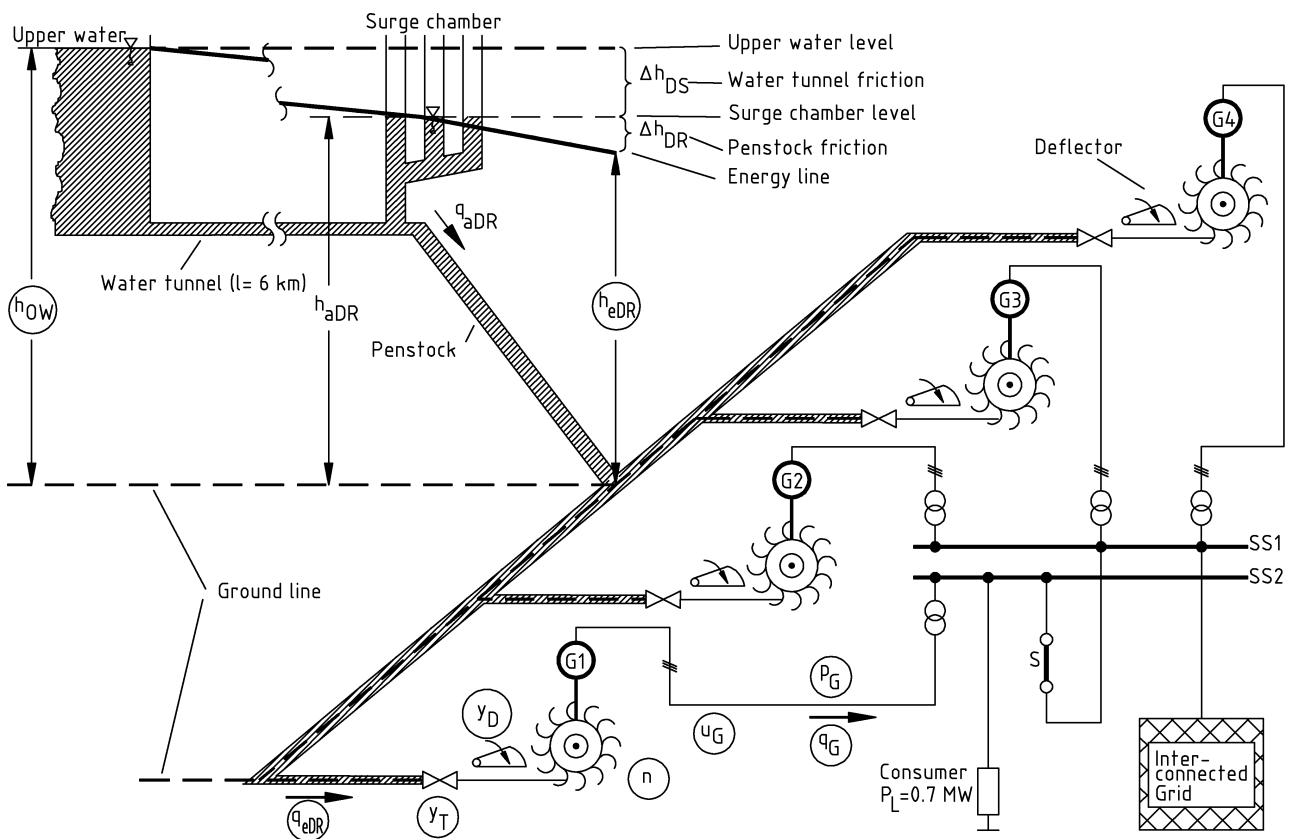

Fig. 2 Scheme of the hydro power plant “Vrutok” in Macedonia

The HPP “Tikves” lies in the southern part of Macedonia, 20 km on the south-west of Kavadarci city at the Tikves accumulation lake. It is a storage plant type.

The HPP “Zvornik” lies in the western part of Serbia, 120 km on the west of Belgrade. It is a run-of-river type and was built in the middle course of the river Drina, 93 km from the mouth of the Drine into the Sava.

The HPP “Bajina Basta” is the largest hydro power plant at the river Drina. This hydro power plant lies 55 km on the south of HPP “Zvornik” and is also a run-

of-river type. The hydro power plants “Zvornik” and “Bajina Basta” are two of three plants which belong to the Public Company “Drinske Hidroelektrane”.

The HPP “Djerdap” lies in the eastern part of Serbia, 230 km on the east of Belgrade. It was built in the river Danube, 943 km upstream from the mouth of the Danube into the Black Sea. The main data of the investigated hydro power plants are shown in Table 1.

Table 1. Main data of the investigated hydro power plants

| | Vrutok | Tikves | Zvornik | Bajina Basta | Djerdap |
|-------------------|---------------------|----------------------|-----------------------|-----------------------|-----------------------|
| number of units | 4 | 4 | 4 | 4 | 6 |
| type of turbines | Pelton | Francis | Kaplan | Francis | Kaplan |
| power (unit) | 37.5 MW | 24 MW | 24 MW | 92 MW | 190 MW |
| voltage | 12 kV | 10.5 kV | 11 kV | 15.65 kV | 17.75 kV |
| rated speed | 500 rpm | 300 rpm | 150 rpm | 136.4 rpm | 71.5 rpm |
| rated flow (unit) | 8 m ³ /s | 30 m ³ /s | 155 m ³ /s | 161 m ³ /s | 850 m ³ /s |
| net height | 525 m | 91 m | 19.3 m | 65.1 m | 28 m |

MEASUREMENTS

The measurements are conducted at only one generator-turbine system in each of the power plants. The other systems treated as similar. As step input for the measurements there has been selected an immediate reduction of the active and reactive power, because this guarantees that all the concerned frequencies of the unit's time response can be identified. As depicted in Fig. 2 the investigated machine delivers energy to the interconnected network via busbar 2 and a bus coupler circuit-breaker. Also connected to busbar 2 is a load of approximately 0.7 MW (some small villages). If isolated operation of the generator is possible one test consists of the following steps:

- adjustment of a defined export via the coupler breaker (active and reactive power);
- opening of the breaker;
- measurement and recording of the transient behaviour of the system until a new stationary operating point is reached.

After the opening of the breaker the system works in isolated operation and has to supply only the small load of the island. In this way the input signal of the system can be understood as a step input.

For the case, that there is no isolated operation possible, as occurred in HPP “Tikves”, “Zvornik”, “Bajina Basta” and “Djerdap” the steps have to be performed by another way. In this case the measurements must take place in normal operation during:

- starting of the unit,

- stopping of the unit,
- changing step by step the setpoint for active power or speed,
- changing step by step the setpoint for reactive power or generator voltage.

As depicted in Fig. 2 and Fig. 3 the circled signals are measured ones. All measured signals of the HPP “Vrutok” are:

- active power p_G
- reactive power q_G
- generator voltage u_G
- excitation voltage u_e
- excitation current i_e
- frequency f
- speed n
- turbine gate position y_T
- deflector/bypass position y_D
- water pressure at the storage lake h_{OW}
- water pressure at turbine input h_{eDr}
- water flow at the turbine input q_{eDr} .

Dependent on the allowed operating mode and the type of used turbine in HPP “Tikves”, “Zvornik”, “Bajina Basta” and “Djerdap” additional the following signals were measured and recorded:

- active power setpoint p_0 or speed setpoint n_0
- reactive power setpoint q_0 or voltage setpoint u_0
- blade angle of Kaplan turbine a_B .

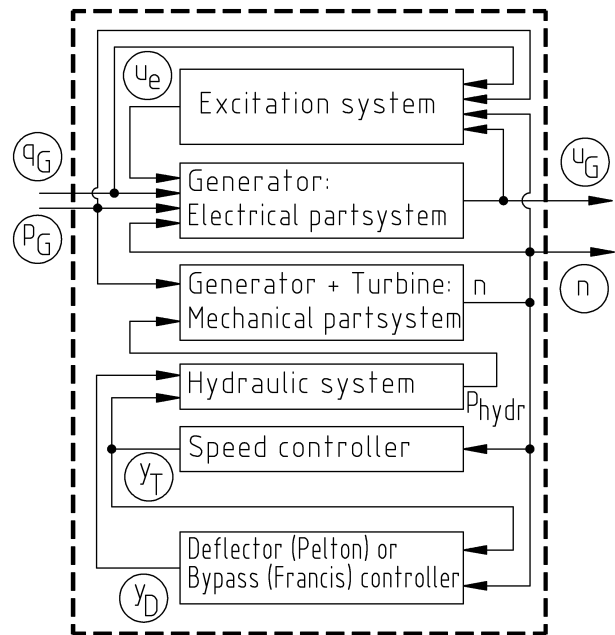

Fig. 3 General block diagram for hydro power plants in isolated operation

The measured signals are recorded by a PC-based Labview system with 16 channels. The sampling rate is 100 ms.

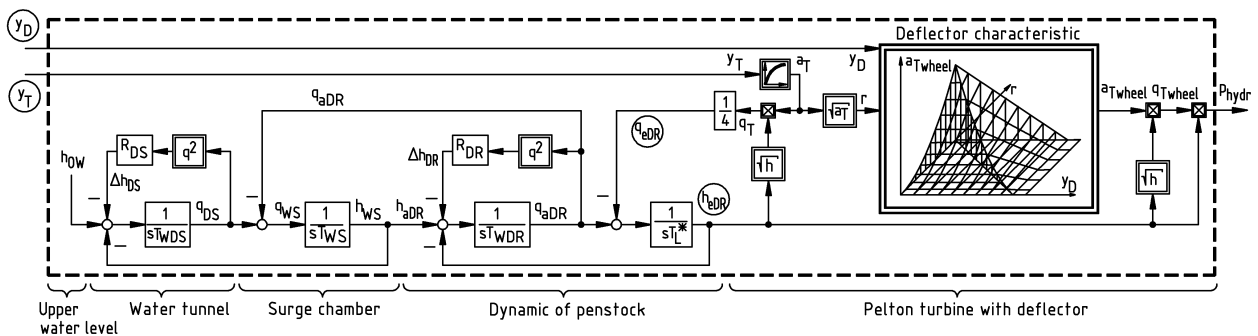

Fig. 4 Hydraulic system of HPP „Vrutok“

MODELLING AND IDENTIFICATION

Using the schemes of the hydro power plants, as for instance depicted in Fig. 2 and all available technical documentations, the models of the different part systems shown in Fig. 3 were developed using the Matlab/Simulink software. The created overall model for each of the plants consists of 14 state variables and 32 unknown parameters which have to be identified. As example the developed model of the hydraulic part for the HPP “Vrutok” [3] is shown in Fig. 4. The circled signals are again measured ones.

The identification is conducted in Matlab using the Least-Square-Method, the principle is shown in Fig. 5. In the first step only the hydraulic part, together with the mechanical part, is identified using the turbine gate position as input and the water pressure and the speed of the turbine as outputs. In the second step, the parameters of the turbine and deflector/bypass controllers are identified using the hydraulic and mechanical system as identified before. In this case the active power is the input and the positions of turbine gate and the deflector are the outputs. In a third step, the electrical part of the generator and the excitation system are identified using the active and reactive power as inputs and the generator voltage, the excitation voltage and the excitation current as outputs.

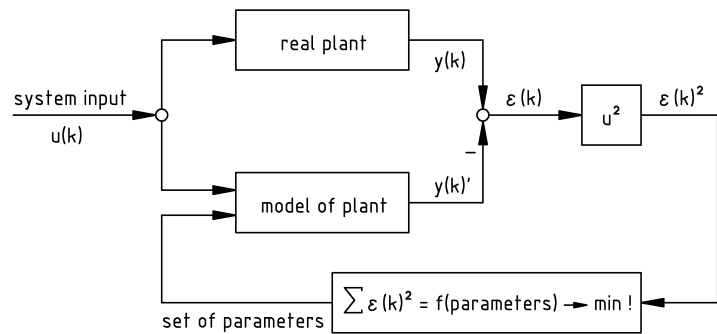

Fig. 5 Least-Square identification method

IDENTIFICATION RESULTS

As example the identified parameters of HPP “Vrutok” of the hydraulic, mechanical, electrical part and some parameters of the speed controller and the excitation system are shown in Table 2.

Table 2. Identified parameters of HPP “Vrutok”

| | | | | | | | | |
|---------------------|--------------------|-------------------|------------------|---------------------|-----------------|-------------------|-------------------|-------------------|
| R_{DS} 0,08 | T_{WDS} 6,7 s | T_{WS} 700 s | R_{DR} 0,02 | T_{WDR} 1,46 s | T_L 0,34 s | k_{kV} 0,043 | k_{pV} 0,1 | k_{qV} 0,054 |
| T_A 6,8 s | x_d 1,5 | x_d' 0,4 | x_d'' 0,22 | x_q 1 | x_q'' 0,24 | T_d' 1,5 s | T_d'' 0,03 s | T_q'' 0,03 s |
| σ_p 3,8 % | T_{ip} 1 s | k_p 9,3 | k_u 22 | k_f 1 | T_f 0,54 s | | | |

For HPP “Vrutok” the simulation results of the identification after an exchange power step of +4 MW are shown in Fig. 6. The input signals are active power p_G and reactive power q_G and the fitted output signals are frequency deviation Δf , excitation voltage u_e , excitation current i_e , turbine gate position y_T and deflector/bypass position y_D . For HPP “Zvornik” some simulation results are shown in Fig. 7. In the active-power-diagram the non-minimal-phase-behaviour is clear to see. During this experiment the generator was all the time interconnected to the serbian grid. The input signal is the speed setpoint n_0 . The output signals are active power p_G , turbine gate position y_T and blade angle y_B .

As depicted, a good correspondence between measurement and simulation can be achieved. The real power plants and the developed practical simulation models are showing nearly the same dynamic behaviour.

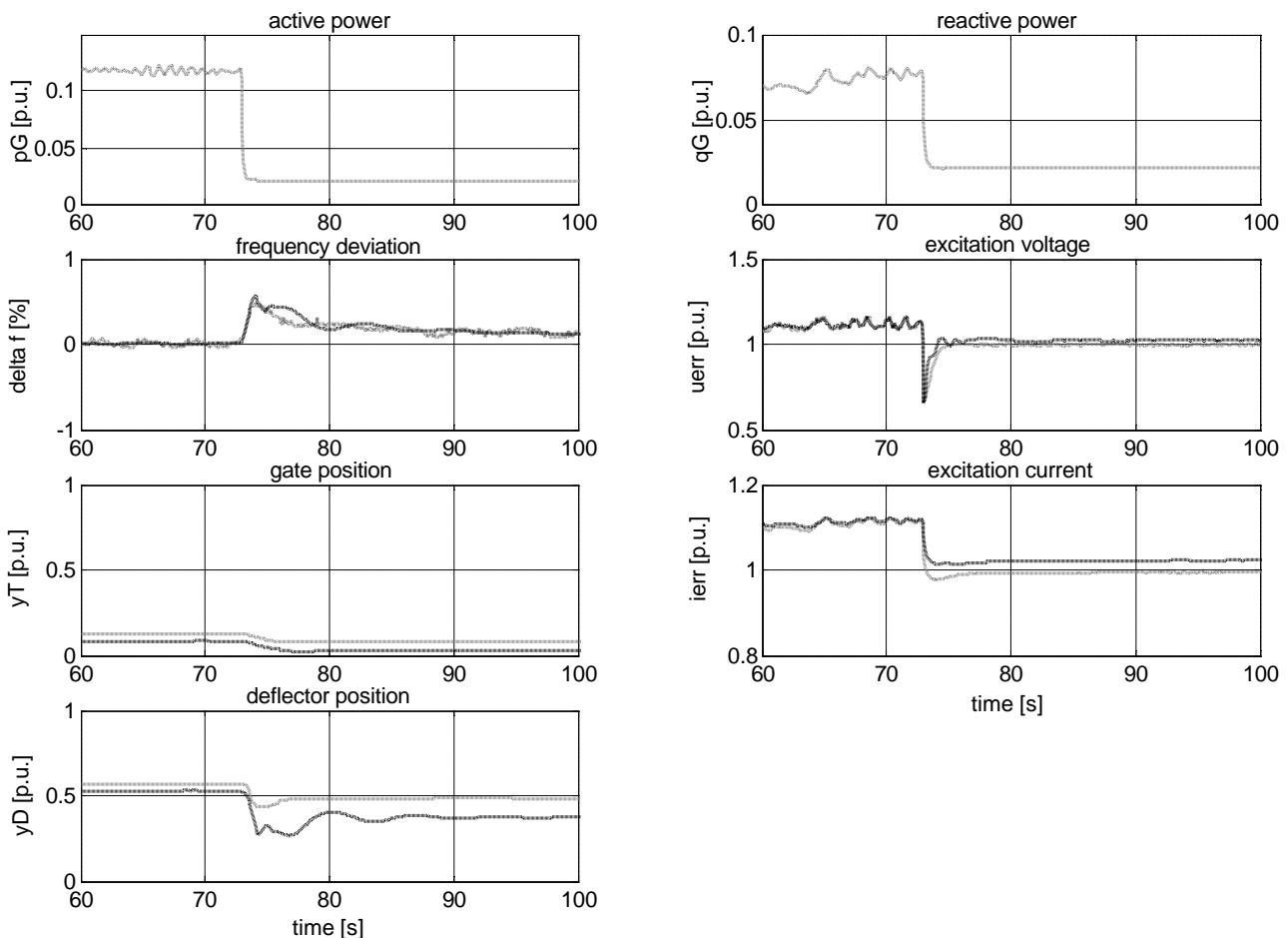

Fig. 6 Comparison of measured (grey) and simulated (black) signals after a +4 MW exchange power step in HPP “Vrutok”

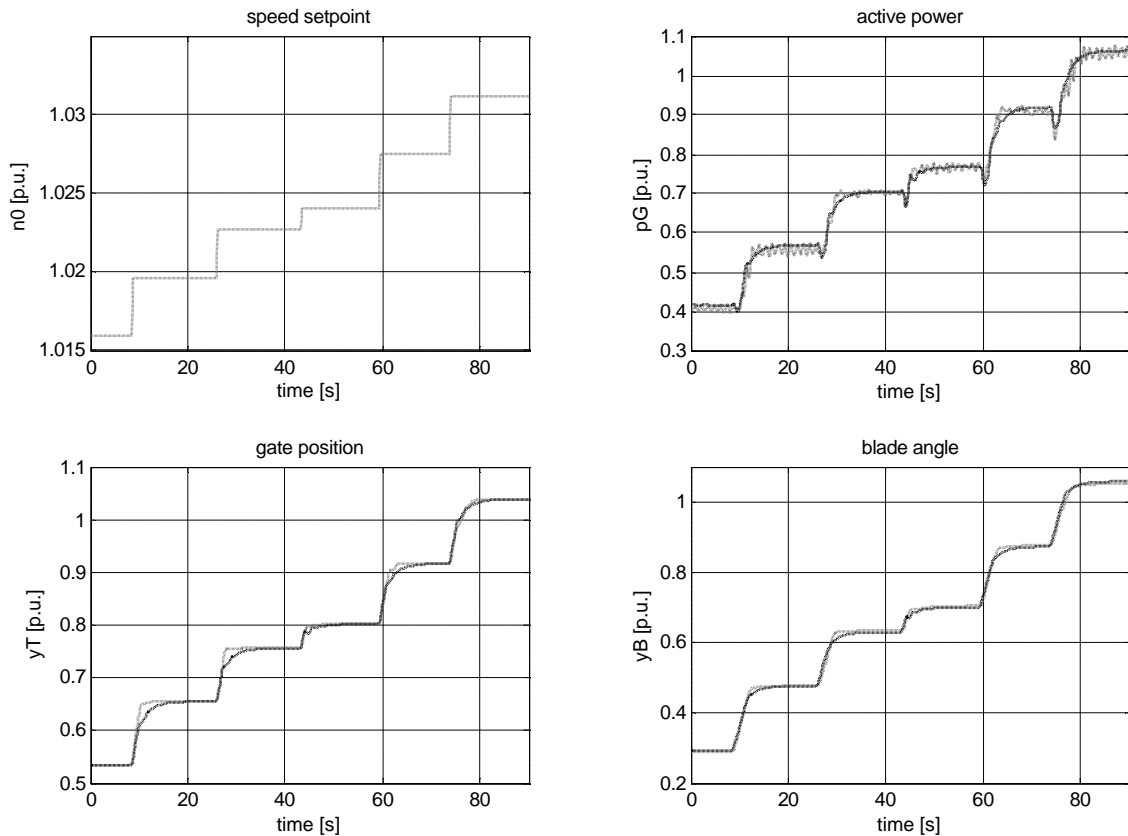

Fig. 7 Comparison of measured (grey) and simulated (black) signals during changing the speed setpoint in HPP “Zvornik”

CONCLUSION

In this contribution the modelling of hydro power plants is presented. The contribution has proved that the practical and user-friendly mathematical model of the complex system, as it is a hydro power plant, can be created. These models can be practically used for expert’s analysis, staff training and can be incorporated in the future in the Energy Management System to be installed in the companies of electrical energy supply in Macedonia (ESM) and Serbia / Montenegro (EPS).

References

- [1] Asal H. P., R. Widmer, H. Weber, E. Welfonder, W. Sattinger. Simulation of the restoration process after black out in the Swiss grid. Bulletin SEV/VSE 83, 22, 1992, pp. 27-34.
- [2] Weber, H., F. Prillwitz, M. Hladky, H. P. Asal. Reality oriented simulation models of power plants for restoration studies. Control Engineering practice, 9, 2001, pp. 805-811.
- [3] Weber, H., V. Fustik, F. Prillwitz, A. Iliev. Practically oriented simulation model for the Hydro Power Plant "Vrutok" in Macedonia. 2nd Balkan Power Conference, 19.-21.06. 2002, Belgrade, Yugoslavia.