

# Dynamic investigation of network restoration by the pumped-storage plant Markersbach in Germany

H. Weber\* M. Krueger\*

\*Institute of Electrical Power Engineering at the University of Rostock,  
Germany (Tel: +49-381-498-7100; e-mail: harald.weber@ uni-rostock.de)

---

**Abstract:** To restore a transmission network after blackout without predetermined voltage by neighbouring transmission systems, the restoration has to proceed from power-station units within the own network area. In small separate networks connecting electrical equipment and consumers can result in unstable operating conditions. Possibly tripped protective measures can cause the breakdown of the restored transmission system in the end. To investigate network restoration, a realistic dynamic model of the extra-high voltage system is needed on a simulation platform. In this way different scenarios of restoration can be analysed from technical points of view. Creating a complete dynamic network model, the dynamic models of the most significant supplying power plants are necessary. The paper presents the results of modelling the black-start capable pumped-storage plant (PSP) Markersbach that is located in eastern part of Germany. Basing on measurements in the PSP Markersbach a dynamic power-station model was developed and its parameters were identified. With the model of the power plant several restoration scenarios proceeding from PSP Markersbach can be investigated regarding their feasibility. This project is a part of cooperation between Vattenfall Europe Transmission GmbH (VE-T) and University of Rostock. The determined possibilities of a successful network restoration are going to be involved in a conception concerning the restoration of VE-T transmission system. This conception will also be used as instruction manual for employee training.

---

## 1. INTRODUCTION

The operation of extra-high voltage systems by transmission system operators (TSO) has become more difficult in Germany during the last years. TSO have to take up new challenges by the deregulation of the European Interconnected Network and by getting through the renewable energy law (German abbreviation EEG). Because of extending electricity trading and ever increasing supply from renewable power plants, especially from wind power stations (Weber et al., 2006), the power flows at the extra-high voltage lines rise. These horizontal load flows involve not only additional transmission and distribution losses, but also the risk of a reduction of system stability. Aggravating add to this renewable generated load flows can in part only be predicted inaccurately. To provide additional transient energy in control areas, there is a strong rise in settling operations of power stations that participate in system regulation. This development has led to an increasing probability regarding the occurrence of system disturbances in general and of system incidents in particular cases. System incidents can be divided in (Rasch, 2004):

- regional supply failure
- stable operation after load shedding

- large-surface system collapse in the interconnected network
- system collapse in the whole interconnected network.

In the Operation Handbook of UCTE and the TransmissionCode 2007 of Association of German network operators (VDN), there are defined the duties of German TSO and electricity generating companies in the case of system incident. TSO have to develop plans for preventive and operative actions for the system service "supply reconstruction".

For investigating the possibilities of network restoration after system incident Vattenfall Europe Transmission GmbH (VE-T) and Vattenfall Europe Generation AG & Co. KG (VE-G) cooperate with the University of Rostock. VE-T is a TSO in Germany that is responsible for the extra-high voltage network in the area of the former East German states, Berlin, and Hamburg (Fig. 1). In 2006 the maximum of vertical network load was at 10.657 MW in the VE-T's transmission system. The maximum of power supply amounted to 14.970 MW in the same year.

## 2. NETWORK RESTORATION

During the last years a lot of major changes have occurred in the VE-T transmission network. The existing conception for

network restoration is now to be checked for its application by investigations with a realistic dynamic network model. Afterward the existing conception is to be adapted to the changed conditions and should the occasion arise is to be extended by new restoration scenarios. To improve the employees' knowledge a clearly structured instruction manual "network restoration" has to be prepared. And a dynamic network model has to be created to enable a realistic training of network restoration.

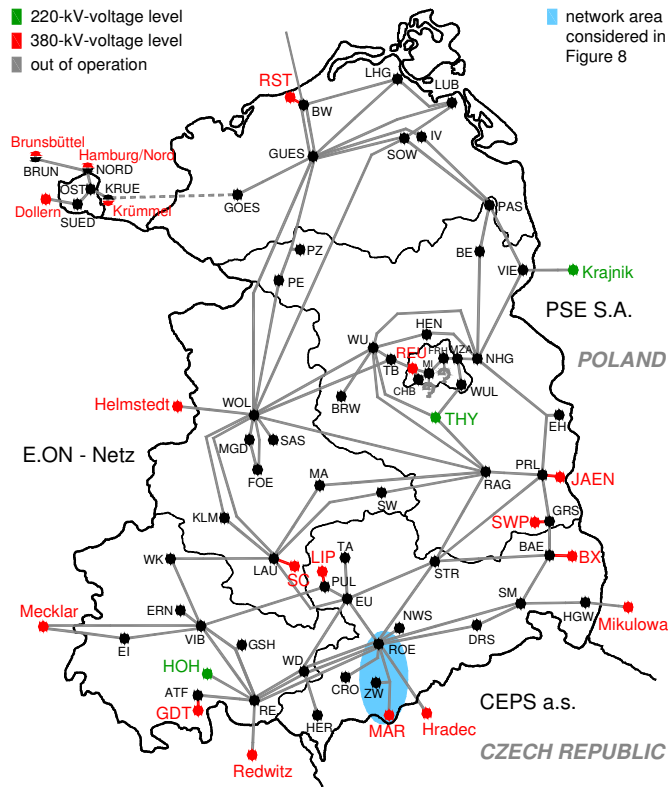

Fig. 1. VE-T transmission network after a possible system collapse

The principle for reconstructing the transmission system after blackout is to restore the supply of consumers as soon as possible. Depending on the arisen network situation the network restoration can be divided in two categories (Rasch, 2004):

a) Network restoration with predetermined voltage from neighbouring transmission systems

- Neighbouring transmission networks are not affected by the system collapse respectively are able to provide voltage at a tie node immediately after the system collapse.
- The restoration of the VE-T transmission network can take place starting at voltage-predetermining tie nodes of neighbouring transmission systems. As Figure 1 shows for the network area of the former East German states and Berlin the tie nodes are Helmstedt, Mecklar, Redwitz, Hradec, Mikulowa, und Krajnik. A restoration of the network area Hamburg can take place proceeding from the tie nodes Brunsbüttel, Hamburg Nord, Krümmel, and Dollern.

b) Network restoration without predetermined voltage from neighbouring transmission systems

- After a system collapse neighbouring transmission systems are not able to provide voltage at a tie node in the foreseeable future.
- The restoration of the VE-T transmission network has to take place starting at power-station units in the own transmission system. For that after a system collapse power stations are required that have steadied themselves in isolated essential auxiliary circuits respectively that are black-start capable. For this case Figure 1 shows the tie nodes in the network area of the former East German states and Berlin where the network restoration could start from. Restoration proceeding from thermal power stations, which have steadied themselves in essential plant auxiliary demand, is possible at the power plants Rostock (RST), Reuter (REU), Jänschwalde (JAEN), Schwarze Pumpe (SWP), Boxberg (BX), Schkopau (SC), and Lippendorf (LIP). If network restoration has to proceed from black-start capable power stations, it will start from the gas-turbine plant Thyrow (THY) or from the pumped-storage plants Hohenwarte (HOH), Goldisthal (GDT) und Markersbach (MAR).

### 3. PROJECT

During islanding, isolated operation, and network restoration there arise dynamic processes that have an effect on system stability. Being able to define the consequences of operational actions in such extreme network situations, simulations often are necessary. Examinations in reality can not be carried out due to dangers and restricted possibilities. Within the framework of cooperation with VE-T the University of Rostock develops a dynamic network model of the VE-T extra-high voltage system on a simulation platform. In this way several scenarios of network restoration can be analysed from technical points of view. With that the proof of technical feasibility can be furnished concerning different plans of network restoration. And problems during the implementation of these plans can be detected. Being able to create a complete dynamic network model, the dynamic models of the most important supplying power plants are necessary. Precise knowledge is required regarding the technical and economic actual state of power stations. For that examinations of separate power plants have to run the principle sequence of model development, measurement, identification, and simulation (Weber et al., 2002).

### 4. MODEL OF PUMPED-STORAGE PLANT MARKERSBACH

#### 4.1 Power Plant

In a first step the dynamic model of the black-start capable pumped-storage plant (PSP) Markersbach of VE-G was developed. The PSP Markersbach is located in the Free State of Saxony in western part of Erzgebirge at the course of river Great Mittweida. It is a cavern-type power station with 6 Francis pump-turbines. With a nominal capacity of

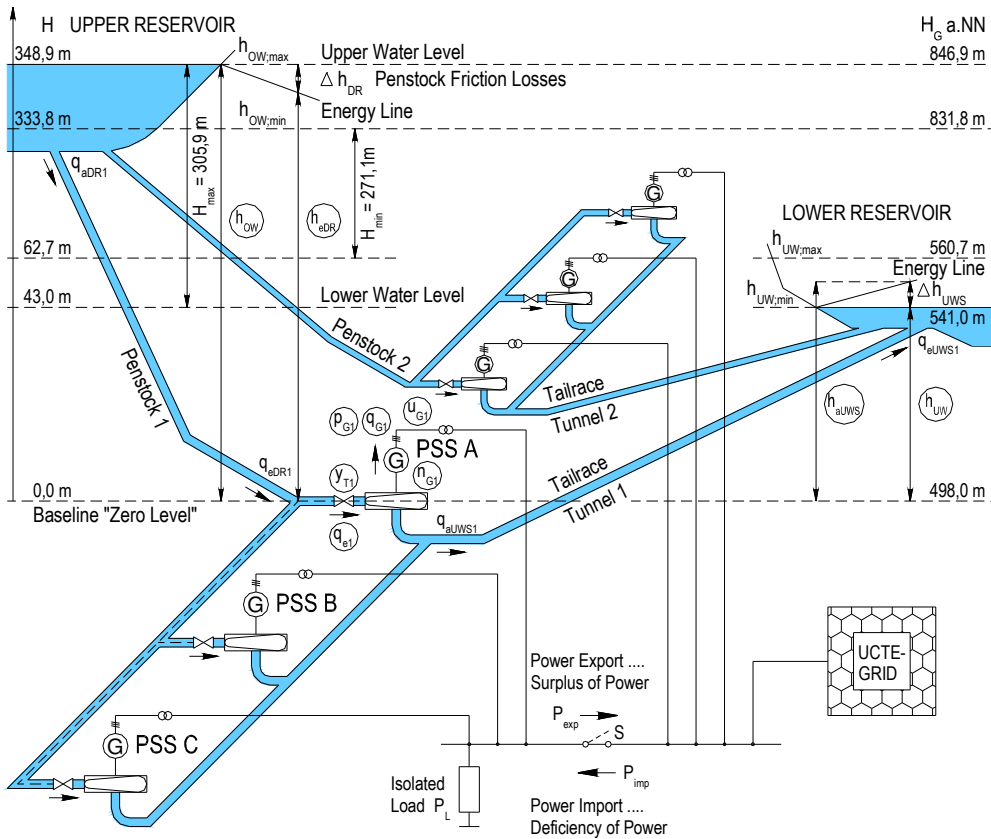

Fig. 2. Plant scheme of PSP Markersbach

1.050 MW (6×175 MW) in turbine operation it is the second largest PSP in Germany. The average output in pump operation is rated at 1.140 MW (6×190 MW). Figure 2 shows the plant scheme. The lower reservoir is formed by the dammed up Great Mittweida. The energy capability of the artificial upper reservoir is rated at 4.018 MWh. The average head amounts 288 m. The 6 pump turbines with vertical axes are connected by 2 penstocks respectively 2 tailrace tunnels to the upper respectively lower reservoir. Every 3 pumped-storage units, 1 penstock and 1 tailrace tunnel form one partial plant. The nominal turbine discharge is rated at 6×70 m<sup>3</sup>/s. Each of the 6 generators feeds via one transformer in Markersbach into the 380-kV-voltage level of the VE-T transmission system.

#### 4.2 Measurement of the Pumped-Storage Plant

On June 6<sup>th</sup>-7<sup>th</sup> 2006 the measurements were conducted by engineers from the University of Rostock and VE-G. The measurements were taken at only one pumped-storage unit. The other 5 units are considered as structurally identical. To determine the characteristic curves of guide-vane system and turbine the examinations were conducted in interconnected operation. During these examinations steady-state operating points were approached and significant technological quantities were captured by measurement. Some of the measured signals are marked in Figure 3 as encircled input and output signals. For determination of dynamic performance experiments were conducted in isolated operation. The principle sequence is shown in Figure 2. In the initial

situation one partial plant of the PSP runs in interconnected operation. The second partial plant is out of operation. By opening tie switch S the first partial plant is separated from network and then only supplies a connected isolated load. At the transition to isolated operation either a deficiency or a surplus of supplied power emerges depending on the operating point of power station before the network splitting. With the aid of its control systems the power station should be able to supply the isolated load solidly after the transition to a new operating point. With the data from the measurements the parameters needed for the modelling of the PSP could be identified.

#### 4.3 Model of the Power Plant

The model of the power plant is a non-linear model. It was implemented in the software package DIGSILENT PowerFactory, a program for network calculation. All physical quantities are used in per unit system (p.u.). The main components of the model are the sub-models: hydraulic and mechanical system (turbine), turbine regulator, voltage regulator, generator, and network model. The principle block

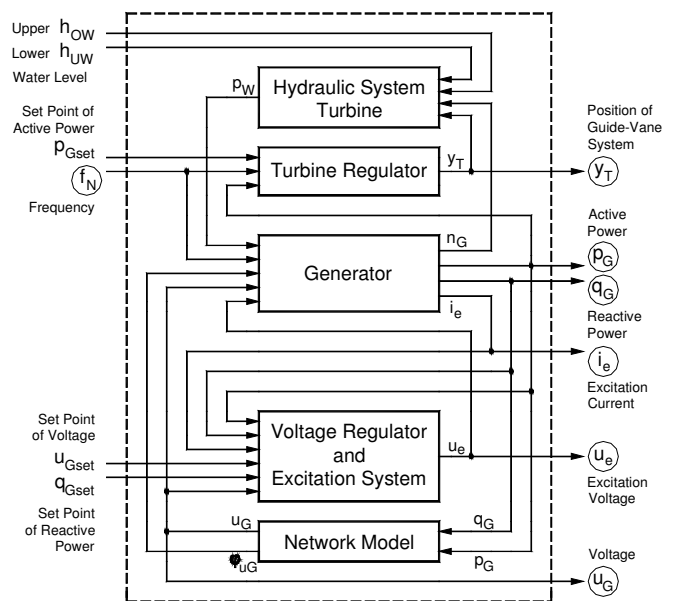

Fig. 3. Block diagram of the power plant model

diagram of the entire model with signal flows between sub-models is presented in Figure 3.

Concerning the sub-model hydraulic and mechanical system of one partial plant (Figure 4) the components penstock, 3 structurally identical Francis pump-turbines, and tailrace tunnel were modelled. The model parts of penstock and tailrace tunnel are able to simulate the inertia of water ( $T_W$ ), the compressibility of water column ( $T_D$ ), and the hydraulic friction losses ( $R$ ) (Weber, 1990). The correlation between guide-vane position and effective flow area of turbine is described by the characteristic curve of guide-vane system  $a_T = f(y_T)$ . In PSP Markersbach the water passes the turbine and flows into the lower reservoir, which is located higher than the Francis pump-turbines. For this reason the pressure difference

$$h_{net} = h_{eDR} - h_{aUWS} \quad (1)$$

is to take as a basis for the calculation of flow. The turbine characteristic  $p_T = f(p_{Hyd})$  shows the transformation of available hydraulic power into useful service output at the turbine shaft. No “shell curve” characteristic of the Francis pump-turbine was available. Due to this the efficiency plot is used, which was determined from the steady-state measurements at a net head of 274 m. For the simulation of dynamic transients the varied flow conditions, occurring in turbine at overspeed, need to be taken into consideration. Thus at overspeed there are modelled a constriction of the effective flow area of turbine ( $\Delta a_T$ ) and additional active losses ( $p_V$ ) due to occurring turbulent flows.

For all pumped-storage sets in PSP Markersbach turbine regulators of the type DTL 595 (Sulzer Hydro) are installed. The block diagram of turbine regulator is shown in Figure 6. The turbine regulator consists of an electronic and a hydro-mechanical part. In interconnected operation it is capable of running in the operating modes opening control or power control (PI controller). If rotational speed deviates from

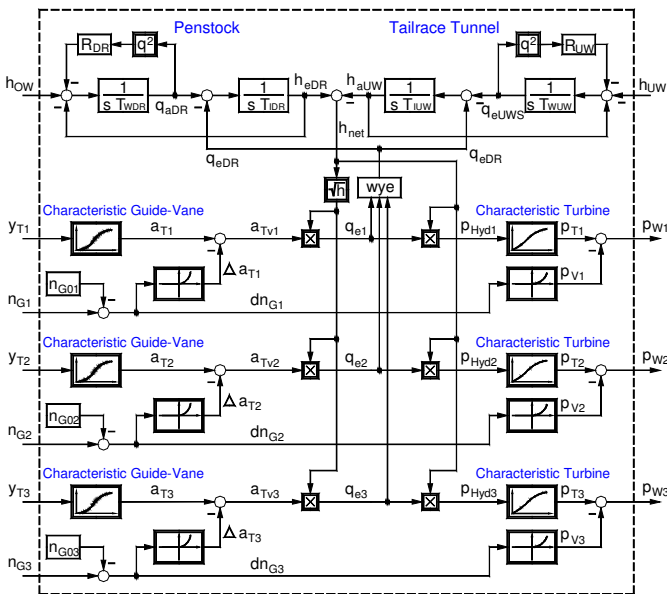

Fig. 4. Block diagram of the hydraulic and mechanical sub-model of a partial plant

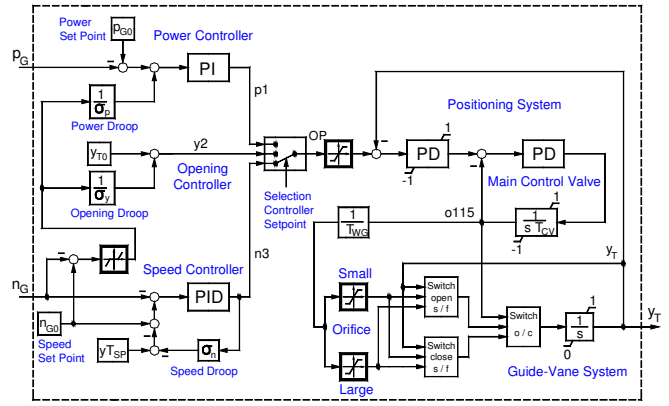

Fig. 5. Block diagram of turbine regulator Sulzer DTL 595 (Francis) in PSP Markersbach

nominal value below an adjustable threshold value, in interconnected operation there will not be made any contribution to speed stabilization. Above the threshold value the contribution to speed stabilization is determined by opening droop respectively power droop. An internal detection of islanding monitors deviations of speed from nominal value. The islanding is recognized either internally in the regulator by passing the dead band or by a binary signal externally given to the regulator. In isolated operation the speed controller is in operation. The speed controller (PID-controller) calculates the output signal of regulator from setpoint/actual point difference of the rotational speed. The speed droop ( $\sigma_n$ ) determines the influence of speed variations on the speed controller output. The servomotor of guide-vane system is adjusted by the main control valve. The control piston of this valve is set by a two-stage positioning system according to the output signal of controller (OP). Due to the positioning forces the regulating units of the main control valve and of the servomotor of guide-vane system are constructed as oil-hydraulic elements. The positions of the main control valve ( $\phi 115$ ) and of the servomotor of guide-vane system ( $y_T$ ) are fed back to the electronic part of DTL 595 by electrical linear position encoders. In PSP Markersbach the opening and closing operations of guide-vane system are determined by 2 operating-point-dependent hydraulic orifices with 2 maximum adjustment speeds.

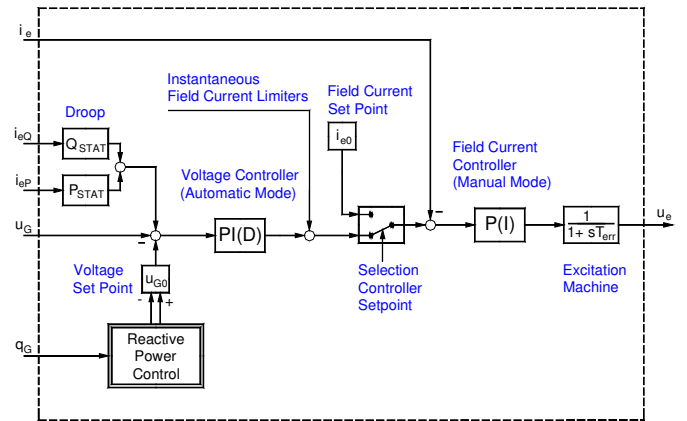

Fig. 6. Block diagram of voltage regulator ELIN GMR3 in PSP Markersbach

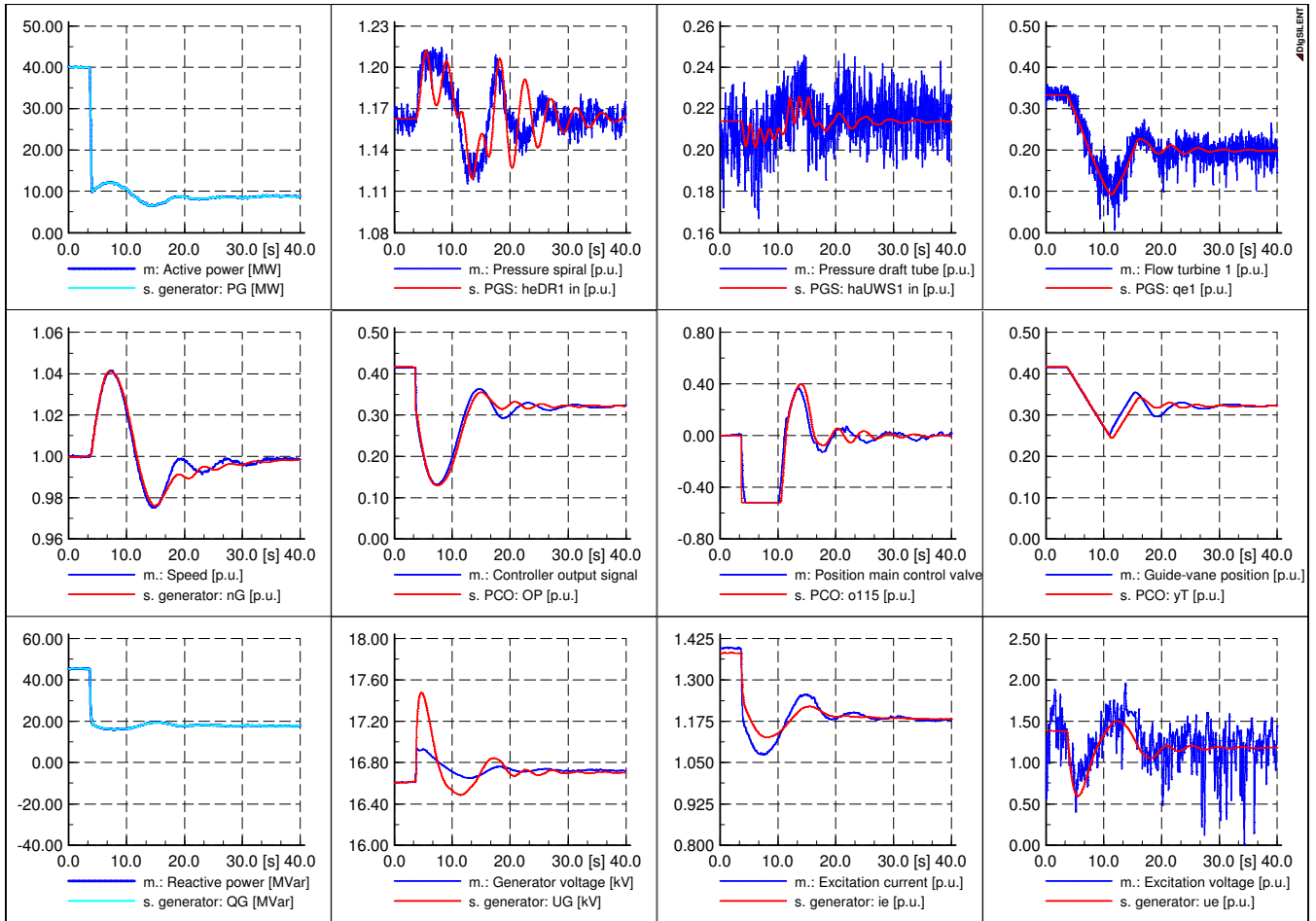

Fig. 7. Result of the identification of entire system for one experiment in isolated operation ( $\Delta P = -31,3$  MW)

In PSP Markersbach the GMR3 of firm ELIN is running as voltage regulator. Figure 6 shows the accompanying block diagram. The excitation system consists of the voltage regulator with series-connected exciter. The voltage regulator is able to be operated either in manual mode (field current control) or in automatic mode (voltage control or reactive load/power factor control). The structure of voltage regulator is made of two loops and regulates the generator voltage to an adjustable voltage set-point. The first loop (voltage control) consists of one PI(D)-controller and leads the subordinate second loop (field current control) by P(I)-action. The different operating modes can be set by the switch of set-point selection. Enabling reactive power distribution to several synchronous machines running in interconnected respectively parallel operation, the reactive droop is summed in addition to the voltage set-point. By that the set point of stator voltage is reduced in dependence on reactive current. An active droop would also be usable, but it is not activated. In automatic operation a master control of reactive load is available in addition to voltage control. It acts on the set point of voltage control and regulates the reactive load to an adjustable set point of reactive load. During isolated operation the voltage regulator runs in the operating mode of voltage control. In this process only the PI-component of voltage regulator is effective. The P-component only is activated in the subordinated field current controller.

#### 4.4 Identification

The power plant model was identified by using the software package DiGSILENT PowerFactory, which provides a routine for parameter identification. The identification process is divided in a few steps. The main parts are the identification of the separate sub-models and the final identification of the entire model. First the above-described sub-models were identified at open control loop. For the identification of parameters and time constants the measured quantities were used that were recorded during the experiments in isolated operation. After the identification of separate sub-models the entire model was identified at closed control loop (Figure 3). Although each sub-model was identified separately at an optima regarding the available measured quantities, an improvement of the model's general performance is expected after the final identification at closed control loop. The variations with time of active power ( $p_G$ ) and reactive power ( $q_G$ ), which were captured at generator during experiments in isolated operation, are used as input signals at final identification. In the network model they are preset to an isolated load as power consumption. After islanding the feeding pumped-storage unit has to react to the changed power demand of isolated load with the aid of its control systems. By activating input signals ( $p_G$ ,  $q_G$ ) the model should simulate the output quantities generator speed ( $n_G$ )



and generator voltage ( $u_G$ ) as well as all the other dynamically relevant quantities in a large degree of correspondence to the measured variations with time. Figure 7 shows the comparison between simulated (red) and measured signals (blue) for one of the experiments in isolated operation. As it can be seen a good agreement with the measurements was achieved for all relevant quantities. Basing on the measurements in PSP Markersbach and on provided power plant documentations a dynamic model of the power plant was developed and identified. The model is capable of describing the entire operating range of power plant correctly.

### 5. NETWORK RESTORATION WITH PSP MARKERSBACH

The developed model of PSP Markersbach was implemented in the detailed network model of VE-T transmission system that is inserted in a simplified UCTE-grid in the network calculation program DIgSILENT PowerFactory. By using the network model certain operation scenarios of PSP Markersbach can be simulated and analysed. Thus several variants of network restoration proceeding from PSP Markersbach were investigated regarding their feasibility with the aid of dynamic root-mean-square value simulations. For network restoration it is required, that the black-start capable PSP Markersbach is started up into no-load operation. For isolated operation the turbine regulator is set at speed control and the voltage regulator is put on voltage control. Figure 8 presents the first steps for one variant of a feasible network restoration that proceeds from PSP Markersbach. The results for the simulation of relevant quantities are presented in Figure 9. The separate restoration steps were executed in the chronological sequence as detailed below:

- t = 0 s: one 175 MW pumped-storage unit has been started up and runs in turbine operation
- t = 5 s: switch-on of 380-kV-transmission line Markersbach - Zwönitz - Röhrsdorf
- t = 30 s: switch-on of three-winding transformer (380/110/30-kV) and consumer (20 MW/ 8 MVar) in Röhrsdorf

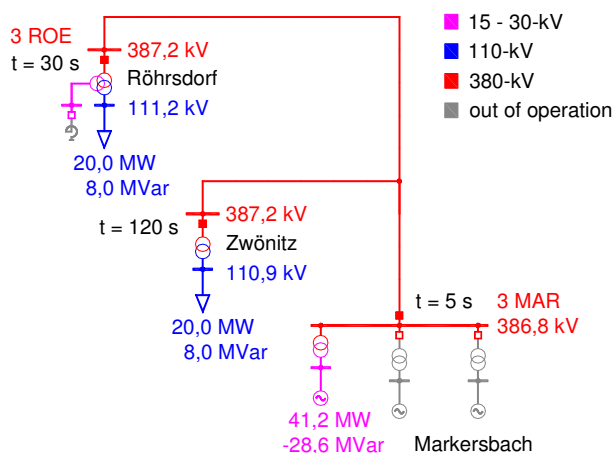

Fig. 8. Network restoration diagram

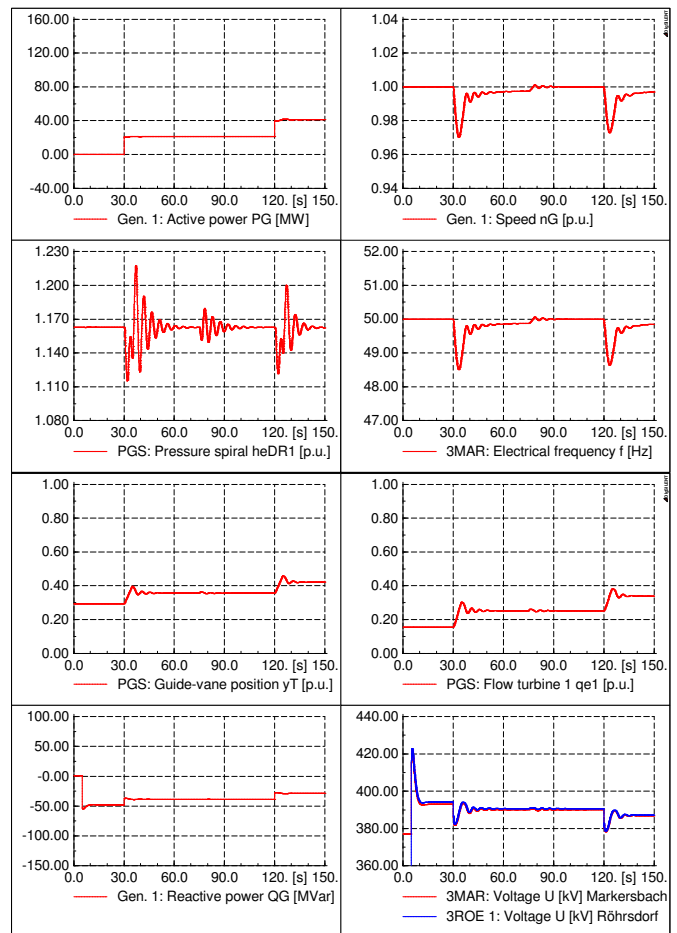

Fig. 9. Results for one simulation of network restoration proceeding from PSP Markersbach

- t = 75 s: correction of the set point of speed
- t = 120s: switch-on of two-winding transformer (380/110-kV) and consumer (20 MW/ 8 MVar) in Röhrsdorf

### REFERENCES

Rasch, P. (2004). Netzwiederaufbaukonzept und -training bei E.ON Netz. In: *VDE Kongress 2004*, Berlin, Germany, 18 – 20 October 2004

Weber, H. (1990). Dynamische Netzreduktion zur Modalanalyse von Frequenz- und Leistungspendungen in ausgedehnten elektrischen Energieübertragungsnetzen. In: *Dissertation University of Stuttgart (Germany)*, 1990

Weber, H., M. Hladky, T. Haase, S. Spreng, C. N. Moser (2002). High quality modelling of hydro power plants for restoration studies. In: *IFAC Conference 2002*, Barcelona, Spain, 21 – 26 June 2002

Weber, H., T. Hamacher, T. Haase (2006). Influence of wind energy on the power station park and the grid. In: *IFAC Conference 2006*, Kananaskis/Alberta, Canada, 25 – 28 June 2006